



Proximity Vibration / Position / Phase Reference Transmitters



Seismic Vibration Transmitters







kmo turbo GmbH • Friedrichstr. 59 • 88045 Friedrichshafen • Germany

Phone: +49 7541 95289-0 • Fax: +49 7541 95289-20 • info@kmo-turbo.de • www.kmo-vibro.com

Table of Contents

ProvibTech's Transmitter Selection Guide	2
TR1101 Seismic Vibration Transmitter	3
Features	3
Specifications	3
Order Information	4
Field-Wiring Diagram.....	5
TR3101 Proximity 3-Wire Transmitter for Radial Shaft Vibration	6
Features	6
Specifications	6
Order Information	7
Field-Wiring Diagram.....	7
TR3102 Proximity 3-Wire Transmitter for Axial Position	8
Features	8
Specifications	8
Order Information	9
Field-Wiring Diagram.....	9
TR4101 Proximity Loop Powered Transmitter for Radial Shaft Vibration	10
Features	10
Specifications	10
Order Information	11
Field-Wiring Diagram.....	12
TR4102 Proximity Loop Powered Transmitter for Axial Position/ Phase Reference	13
Features	13
Specifications	13
Order Information	14
Field-Wiring Diagram.....	15
TM016 Velocity/Acceleration Vibration Transmitter	16
Introduction.....	16
Features	16
Electrical	17
Physical	17
Order Information	18
Field-Wiring Diagram.....	19
Accessories	20
Accessories: TM900 Power Converter	21
Specifications	21
Order Information	21

ProvibTech's Transmitter Selection Guide

Model Number	TR1101	TR3101 TR3102	TR4101 TR4102	TM016
				
Acceleration (g's)	•			•
Velocity (ips/sec, mm/sec)	•			•
Displacement (mils, um)	•	•	•	
Vibration Measurements				
Radial Vibration		TR3101	TR4101	
Axial Position		TR3102	TR4102	
Phase Reference			TR4102	
Case Vibration	•			•
Sensor Interfaces				
Built in Accelerometer				•
Proximity Probe (5mm, 8mm, and 11mm)		•	•	
Accelerometer	•			
Velocity Transducer	•			
Available Outputs				
4-20mA Output	•	•	•	•
Buffered Output (3 meters)			•	•
Buffered Output (300 meters)	•	•		
Available Features				
Loop Powered (2- Wire) Transmitter			•	•
3-Wire Transmitter	•	•		
Hazardous Rating (CSA, ATEX) Explosion Proof, Class I, Class II, Div.1, Groups (A-G), EExdIICT4				•
Hazardous Rating (CSA, ATEX) Intrinsically Safe, EExialIICT4			•	•
Hazardous Rating (CSA), non-incendive, Class I, Div.2, Groups (A-D, T4)			•	
Environmental Rating- NEMA 4 or IP65				•
Low Pass and High Pass Filter				•
Warranty- 5 years	•	•	•	•

• = Complete Offering

TR1101 Seismic Vibration Transmitter

The TR1101 is a cost-effective solution for monitoring case vibration on balance of plant machines. The TR1101 conditions the signal from an accelerometer or velocity transducer and provides a 4-20mA output in acceleration, velocity or displacement.

Features

- ✓ Measures machinery case vibration
- ✓ 4-20mA output in acceleration, velocity or displacement
- ✓ Buffered output up to 300 meters (1,000 feet)
- ✓ Compatible with other manufacturers' sensors (accelerometer or velocity sensor)
- ✓ Aluminum cast (copper free) case with epoxy potting for better environmental protection and reliability
- ✓ Compact size

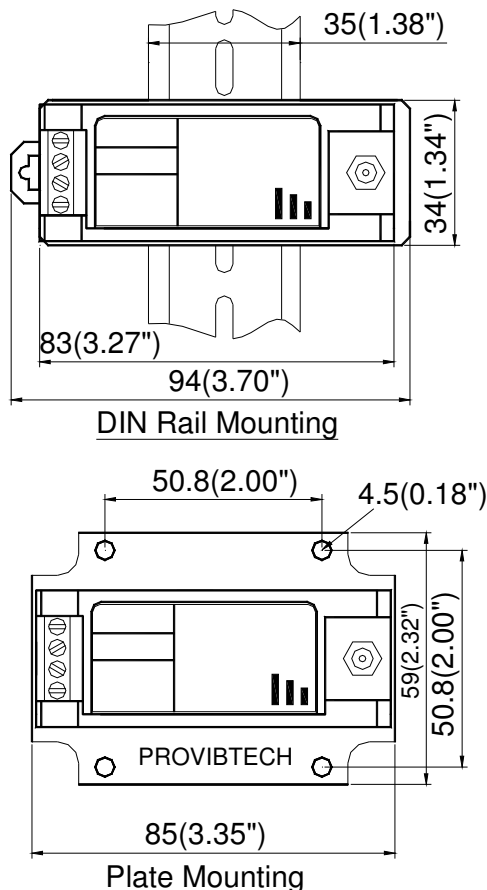

Specifications

Electrical

Power Supply:

22-30VDC, 100mA (Non isolated)

Frequency Response (± 3 dB):

Acceleration: 2.0 - 10 KHz

Velocity: 2 - 10 KHz (velocity sensor)

Velocity: 10 - 5 KHz (accelerometer)

Displacement: 10 - 3 KHz (velocity sensor)

Acceleration (low frequency): 1.0 - 100Hz

Velocity (low frequency): 1.0 - 100Hz (TM079VD)

Displacement (low frequency): 1.0 - 100Hz (TM079VD)

Sensor Interface:

Sensitivity:

100mV/g nominal for accelerometer or

4.0mV/mm/sec (100mV/in/sec) nominal for velocity sensor

40mV/mm/sec (1000mV/in/sec) nominal for velocity

TM079VD or 4mV/ μ m (100mV/mil) nominal for displacement TM079VD

Current Source:

Nominal 4mA@24VDC

Connectors:

GAP/Buf: gap and buffered output

SIG: sensor signal

COM: signal com

4-20mA: 4-20mA output

Electrical specifications continued

Buffered Output:

- Original vibration, un-filtered
- Impedance: 100Ω
- Maximum cable distance: 300m (1,000ft)
- Sensitivity: same as the sensor

Overall Vibration:

- 4-20mA, source
- Driving load resistance up to 750Ω

System Self-test:

- System OK: output 4-20mA
- System Not OK: output < 3.0mA

Physical

- Height: 75mm (2.95")
- Weight: 1.0kg (2.0 lbs)

Environmental

Temperature:

- Operation: -40°C to +70°C
- Storage: -40°C to +100°C

Humidity:

- 90% non-condensing

Order Information

*Factory Default

TR1101-AXX-EXX-GXX

AXX: Full Scale

- A00*: 0 - 200um pk-pk
- A01: 0 - 500um pk-pk
- A02: 0 - 100um pk-pk
- A03: 0 - 10mil pk-pk
- A04: 0 - 25mil pk-pk
- A05: 0 - 5.0mil pk-pk
- A06: 0 - 50mm/s pk
- A07: 0 - 100mm/s pk
- A08: 0 - 20mm/s pk
- A09: 0 - 2.0ips pk
- A10: 0 - 4.0ips pk
- A11: 0 - 1.0ips pk

AXX: Full Scale continued

- A12: 0 - 5.0g pk
- A13: 0 - 10g pk
- A14: 0 - 5.0g pk (low frequency)
- A15: 0 - 10g pk (low frequency)
- A16: 0 - 50mm/s pk (low frequency, E01, E04)
- A17: 0 - 100mm/s pk (low frequency, E01, E04)
- A18: 0 - 500um pk-pk (low frequency, E04)
- A19: 0 - 200um pk-pk (low frequency, E04)
- A20: 0 - 2.0ips pk (low frequency, E04)
- A21: 0 - 4.0ips pk (low frequency, E01, E04)
- A22: 0 - 20mil pk-pk (low frequency, E04)
- A23: 0 - 10mil pk-pk (low frequency, E04)
- A24: 0 - 2.0ips (50 mm/s) rms
- A25: 0 - 1.0ips (25 mm/s) rms
- A26: 0 - 0.8ips (20 mm/s) rms
- A27: 0 - 0.5ips (12.5 mm/s) rms

EXX: Sensor Type (not included)

- E00*: Accelerometer TM0782A, TM0783A, TM0784A, TM0785A, TM0786A or any current mode accelerometer with 100mV/g
- E01: Velocity sensor TM0793V, TM0796V or any current mode velocity sensor with 4mV/mm/sec
- E02: 330500, 330525 velocity sensor
- E03: 330750 velocity sensor
- E04: TM079VD low frequency sensor

GXX: Mount

- G00*: DIN rail mount
- G01: Plate mount

TR1101 Accessories

The TR1101 requires an external accelerometer or velocity sensor to work as a system.

TM0782A, TM0783A, TM0784A, TM0785A, TM0786A:
Accelerometer

TM0793V, TM0796V: Velocity sensor

TM079VD: Low frequency velocity and displacement sensor

TM900: Power converter

TM0200: 3-1/2 digit display unit

Field-Wiring Diagram

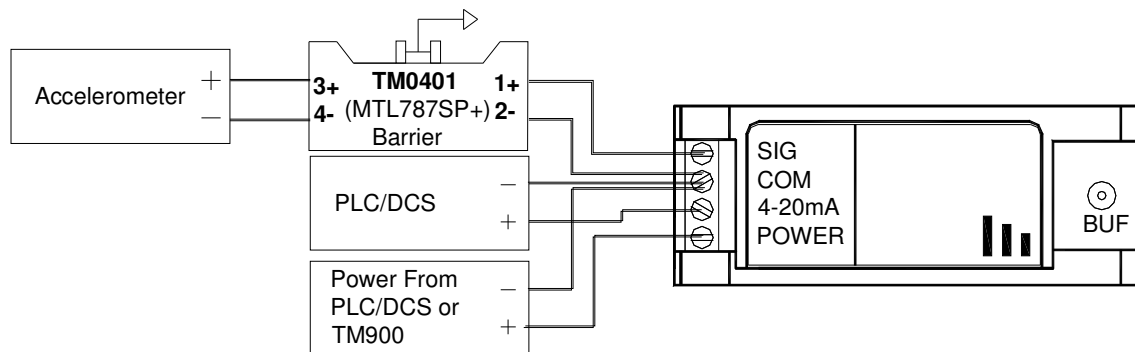
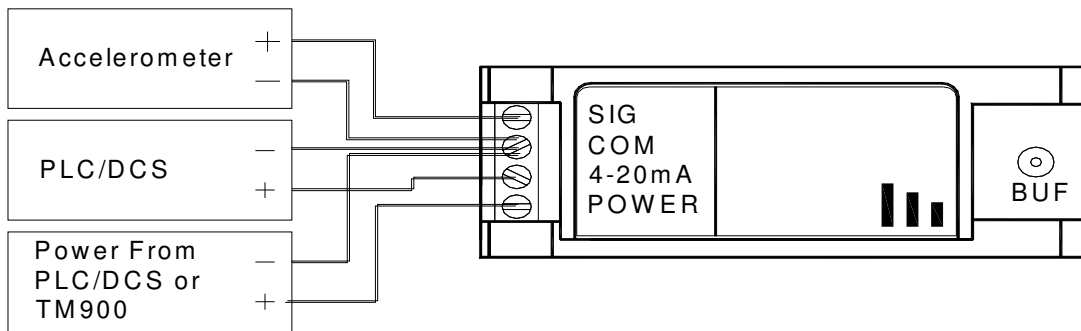

Note:

Other barriers available:

TM0402: (STAHL 9001/51-280-091-141)

TM0407: (STAHL 9160/13-11-11)

TR3101 Proximity 3-Wire Transmitter for Radial Shaft Vibration

The TR3101 is a cost-effective solution for monitoring the radial vibration on balance of plant machines. The TR3101 combines the proximity probe driver and the signal conditioning circuit into one package. It works with the proximity probe and extension cable as a system.

Features

- ✓ Does not require proximity probe driver
- ✓ Buffered output/GAP will transmit signal up to 300 meters (1,000 feet)
- ✓ Compatible with other manufacturers' proximity probes (5mm, 8mm and 11mm)
- ✓ Aluminum cast (copper free) case with epoxy potting for better environmental protection and reliability
- ✓ Same size as a proximity probe driver

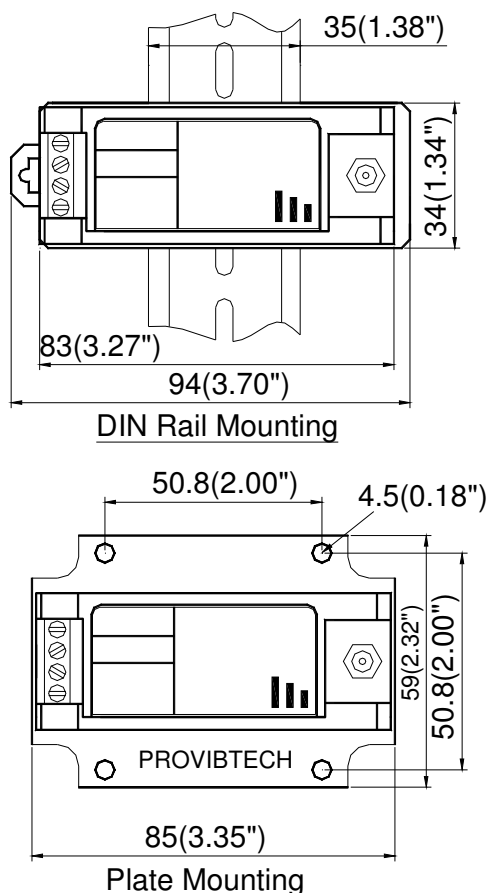

Specifications

Electrical

Power Supply:

20-30VDC

Frequency Response (± 3 dB):

2.0 - 3,000Hz

Probe and cable:

5 meter or 9 meter proximity probe and extension cable works with 5mm, 8mm, and 11mm probes

Proximity probe includes: TM0180, TM0105, TM0110, 3300, 7200, 990 series

Sensor Linear Range (reference with ANSI 4140 steel):

5mm, 8mm probe: 2.0 mm (80mil)

Approximately 0.25mm (10mil) to 2.25mm (90mil)

11mm probe: 4.0mm (160mil)

Approximately 0.4mm (15mil) to 4.4mm (175mil)

Overall Vibration:

4-20mA; Source

Buffered Output/ GAP:

Original vibration, un-filtered

Nominal: 2-18VDC

Impedance: 500 Ω

Maximum cable distance: 300m (1,000ft)

Sensitivity: 8.0mV/ μ m (200mV/mil) nominal

Maximum Load:

500 Ω

Isolation:

> 500Vrms; circuit to case

System OK:

System OK: output 4-20mA

System Not OK: output < 3.0mA

Physical

Height: 75mm (2.95")

Weight: 0.5 kg (1.0 lb)

Proximity Transmitters and Seismic Vibration Transmitters

Environmental

Temperature:

Operation: -40°C to +70°C

Storage: -40°C to +100°C

Humidity:

90% non-condensing

Order Information

* Factory default

Standard configuration:

TR3101-A00-E00-G00-S00

8mm probe:

TM0180-07-00-05-10-02

Extension cable:

TM0181-040-00

TR3101-AXX-EXX-GXX-SXX

AXX: Full Scale

A00*: 0 - 200um (8.0mil) pk-pk

A01: 0 - 500um (20mil) pk-pk

A02: 0 - 100um (4.0mil) pk-pk

A03: 0 - 250um (10mil) pk-pk

A04: 0 - 630um (25mil) pk-pk

A05: 0 - 125um (5.0mil) pk-pk

EXX: Probe and Cable (not included)

E00*: TM0180, 8mm Probe, 5m Cable

E01: TM0180, 8mm Probe, 9m Cable

E02: 3300, 8mm Probe, 5m Cable

E03: 3300, 8mm Probe, 9m Cable

E04: 7200, 8mm Probe, 5m Cable

E05: 7200, 8mm Probe, 9m Cable

EXX: Probe and Cable continued

E06: TM0105, 5mm Probe, 5m Cable

E07: TM0105, 5mm Probe, 9m Cable

E08: TM0110, 11mm Probe, 5m Cable

E09: TM0110, 11mm Probe, 9m Cable

E10: 3300, 11mm Probe, 5m Cable

E11: 3300, 11mm Probe, 9m Cable

E12: 7200, 11mm Probe, 5m Cable

E13: 7200, 11mm Probe, 9m Cable

E14: 3309 Probe, 5m Cable

E15: 3309 Probe, 7m Cable

GXX: Mount

G00*: DIN rail mount

G01: Plate mount

SXX: Approval

S00*: CE Mark

TR3101 Accessories

The TR3101 requires a proximity probe and extension cable to work as a system.

TM0180: 8mm probe

TM0105: 5mm probe

TM0110: 11mm probe

TM0181: Extension cable

TM900: Power converter

TM0200: 3-1/2 digit display unit

KS01: Probe holding system for reverse-mount probes

KS02: GAP tester for comfortable setting of probe distance

KS04: LoopChecker for dynamic testing of the complete measurement circuit

KS05: SensiChecker for easy determination of the loop sensitivity

BNC-3 : BNC adaptor for portable data collector

Field-Wiring Diagram

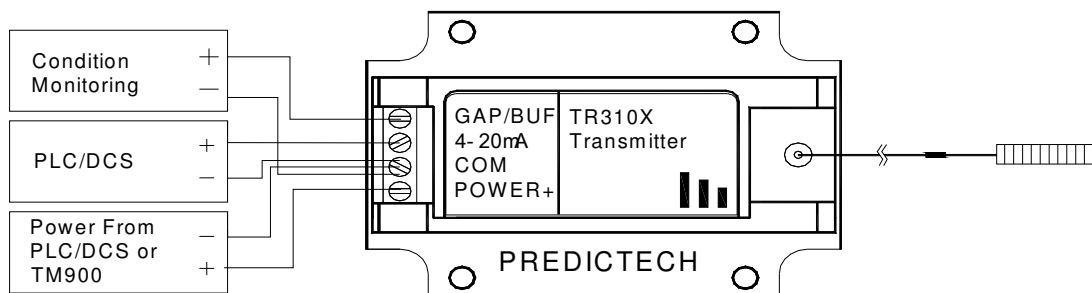

TR3102 Proximity 3-Wire Transmitter for Axial Position

The TR3102 is a cost-effective solution for monitoring the axial position or phase reference on balance of plant machines. The TR3102 combines the proximity probe driver and the signal conditioning circuit into one package. It works with the proximity probe and extension cable as a system.

Features

- ✓ Does not require proximity probe driver
- ✓ Buffered output/GAP will transmit 300 meters (1,000 feet)
- ✓ Compatible with other manufacturers' proximity probes (5mm, 8mm and 11mm)
- ✓ Aluminum cast case (copper free) with epoxy potting for better environmental protection and reliability
- ✓ Same size as a proximity probe driver

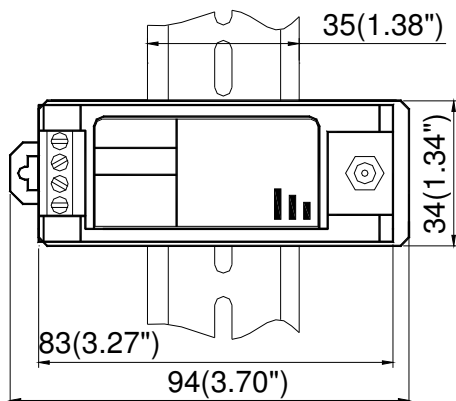

DIN Rail Mounting

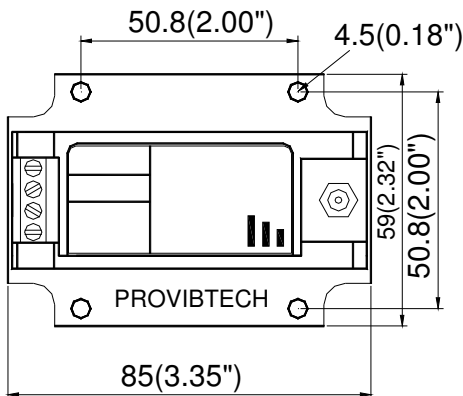

Plate Mounting



Specifications

Electrical

DCS or PLC Power Supply:

20-30VDC

Sensor Interface:

Connection:

Special 95Ω coaxial cable with connector

Probe:

5 meter or 9 meter proximity probe and extension cable works with 5mm, 8mm, and 11mm probes

Proximity probe includes: TM0180, TM0105, TM0110, 3300, 7200, 990 series.

Sensor Linear Range (reference with AISI 4140 steel):

5mm, 8mm probe: 2.0 mm (80mil)

Approximately 0.25mm (10mil) to 2.25mm (90mil)

11mm probe: 4.0mm (160mil)

Approximately 0.4mm (15mil) to 4.4mm (175mil)

4-20mA Transmission:

2-wire, source

Buffered Output (GAP V):

Raw position signal

Nominal 2-18VDC

Impedance: 1,000Ω

Maximum cable distance: 300m (1,000ft)

Sensitivity: 8.0mV/um (200mV/mil) nominal

Frequency response: 0 - 10 KHz

Maximum Load:

500Ω

System Self-test:

System OK: output 4-20mA

System Not OK: output < 3.0mA

Physical

Height: 75mm (2.95")

Weight: 1.0kg (2.0 lbs)

Proximity Transmitters and Seismic Vibration Transmitters

Environmental

Temperature:

Operation: -40°C to +70°C

Storage: -40°C to +100°C

Humidity:

90% non-condensing

Order Information

* Factory default

Standard configuration:

TR3102-E00-G00-S00

8mm probe:

TM0180-07-00-05-10-02

Extension cable:

TM0181-040-000

TR3102-EXX-GXX-SXX

EXX: Probe and Cable (not included)

- E00*: TM0180, 8mm Probe, 5m Cable
- E01: TM0180, 8mm Probe, 9m Cable
- E02: 3300, 8mm Probe, 5m Cable
- E03: 3300, 8mm Probe, 9m Cable
- E04: 7200, 8mm Probe, 5m Cable
- E05: 7200, 8mm Probe, 9m Cable
- E06: TM0105, 5mm Probe, 5m Cable
- E07: TM0105, 5mm Probe, 9m Cable
- E08: TM0110, 11mm Probe, 5m Cable
- E09: TM0110, 11mm Probe, 9m Cable
- E10: 3300, 11mm Probe, 5m Cable
- E11: 3300, 11mm Probe, 9m Cable
- E12: 7200, 11mm Probe, 5m Cable
- E13: 7200, 11mm Probe, 9m Cable
- E14: 3309 Probe, 5m Cable
- E15: 3309 Probe, 7m Cable

G00: DIN rail mount, measure position

G01: Plate mount, measure position

SXX: Approval

S00*: CE

TR3102 Accessories

The TR3102 works with a proximity probe and extension cable.

TM0180: 8mm probe

TM0105: 5mm probe

TM0110: 11mm probe

TM0181: Extension cable

TM900: Power converter

TM0200: 3-1/2 digit display unit

KS01: Probe holding system for reverse-mount probes

KS02: GAP tester for comfortable setting of probe distance

KS04: LoopChecker for dynamic testing of the complete measurement circuit

KS05: SensiChecker for easy determination of the loop sensitivity

BNC-3 : BNC adaptor for portable data collector



Field-Wiring Diagram

GXX: Mount/ Function

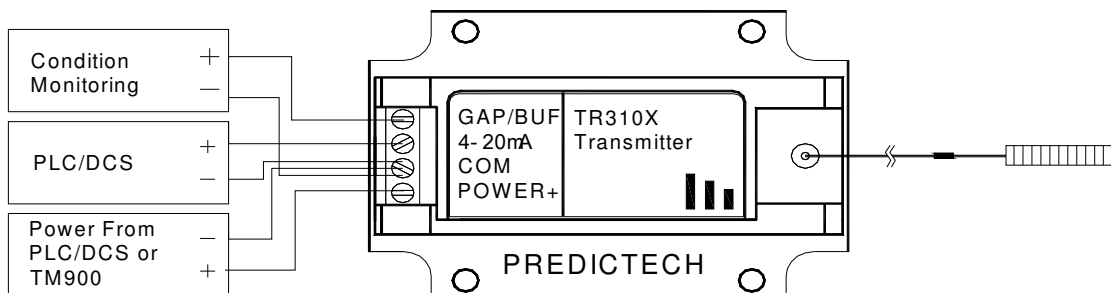

TR4101 Proximity Loop Powered Transmitter for Radial Shaft Vibration

The TR4101 is a cost-effective solution for monitoring the radial vibration on the shaft of balance of plant machines. The TR4101 combines the proximity probe driver and the signal conditioning circuit into one package. It works with a proximity probe and extension cable as a system.

Features

- ✓ **Loop powered transmitter**
- ✓ **Does not require proximity probe driver**
- ✓ **Buffered output/ GAP**
- ✓ **Compatible with other manufacturers' proximity probes (5mm, 8mm and 11mm)**
- ✓ **Aluminum cast case (copper free) with epoxy potting for better environmental protection and reliability**
- ✓ **Same size as a proximity probe driver**

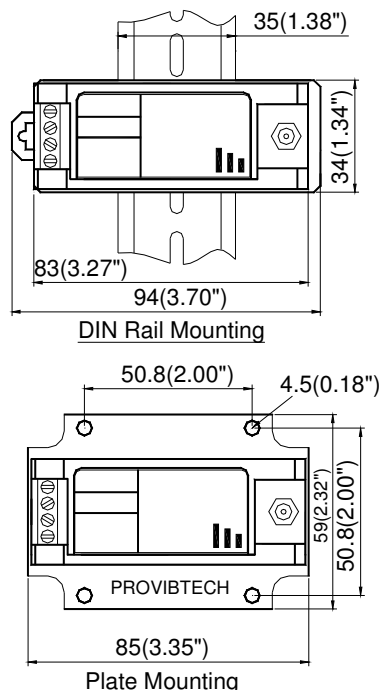

Specifications

Electrical

Power Supply:
16-30VDC
Frequency Response ($\pm 3dB$):



2.0 - 3,000Hz

Probe and Cable:

5 meter or 9 meter proximity probe and extension cable works with 5mm, 8mm, and 11mm probes

Proximity probe includes: TM0180, TM0105, TM0110, 3300, 7200 and 990 series

Sensor Linear Range (reference with AISI 4140 steel):

5mm, 8mm probe: 2.0 mm (80mil)

Approximately 0.25mm (10mil) to 2.25mm (90mil)

11mm probe: 4.0mm (160mil)

Approximately 0.4mm (15mil) to 4.4mm (175mil)

Overall Vibration:

4-20mA

2-wire, load

Buffered Output/ GAP:

Original vibration, un-filtered

Nominal: 2-18VDC

Impedance: 20 k Ω

Maximum cable distance: 3.0m (10ft)

Sensitivity: 8.0mV/ μ m (200mV/mil) nominal

Electrical specifications continued

Maximum Load:

50 \times (Vs-16)

Where Vs is the system power supply

Isolation:

> 500Vrms; circuit to case

System OK:

System OK: output 4-20mA

System Not OK: output < 3.6mA

Physical

Height: 75mm (2.95")

Weight: 0.5 kg (1.0 lb)

Environmental

Temperature:

Operation: -40°C to +70°C

Storage: -40°C to +100°C

Humidity:

90% non-condensing

Order Information

* Factory default

Standard configuration:

TR4101-A00-E00-G00-S00

8mm probe:

TM0180-07-00-05-10-02

Extension cable:

TM0181-040-00

TR4101-AXX-EXX-GXX-SXX

AXX: Full Scale

A00*: 0 - 200um (8.0mil) pk-pk

A01: 0 - 500um (20mil) pk-pk

A02: 0 - 100um (4.0mil) pk-pk

A03: 0 - 250um (10mil) pk-pk

A04: 0 - 630um (25mil) pk-pk

A05: 0 - 125um (5.0mil) pk-pk

EXX: Probe and Cable (not included)

E00*: TM0180, 8mm Probe, 5m Cable

E01: TM0180, 8mm Probe, 9m Cable

E02: 3300, 8mm Probe, 5m Cable

E03: 3300, 8mm Probe, 9m Cable

E04: 7200, 8mm Probe, 5m Cable

E05: 7200, 8mm Probe, 9m Cable

E06: TM0105, 5mm Probe, 5m Cable

E07: TM0105, 5mm Probe, 9m Cable

E08: TM0110, 11mm Probe, 5m Cable

E09: TM0110, 11mm Probe, 9m Cable

E10: 3300, 11mm Probe, 5m Cable

EXX: Probe and Cable continued

E11: 3300, 11mm Probe, 9m Cable

E12: 7200, 11mm Probe, 5m Cable

E13: 7200, 11mm Probe, 9m Cable

E14: 3309 Probe, 5m Cable

E15: 3309 Probe, 7m Cable

GXX: Mount

G00*: DIN rail mount

G01: Plate mount

SXX: Hazardous Area

S00*: Without approval. CE

S01: Multiple approvals

ATEX: II1G, EEx iaIICT4@Ta=-40°C ~ +70°C

KEMA06ATEX0217X

CSA: Non-incendive, Class I, Div. 2,

Groups A, B, C, D & T4

CSA: Intrinsically safe, Class I, Div. I,

Groups A, B, C & D, T4

PCEC: Ex iaIICT4

GOST R: 0ExiaIICT4X

CE

TR4101 Accessories

The TR4101 requires a proximity probe and extension cable to work as a system.

TM0180: 8mm probe

TM0105: 5mm probe

TM0110: 11mm probe

TM0181: Extension cable

TM0200: 3-1/2 digit display unit

KS01: Probe holding system for reverse-mount probes

KS02: GAP tester for comfortable setting of probe distance

KS04: LoopChecker for dynamic testing of the complete measurement circuit

KS05: SensiChecker for easy determination of the loop sensitivity

BNC-2 : BNC adaptor for portable data collector



Field-Wiring Diagram

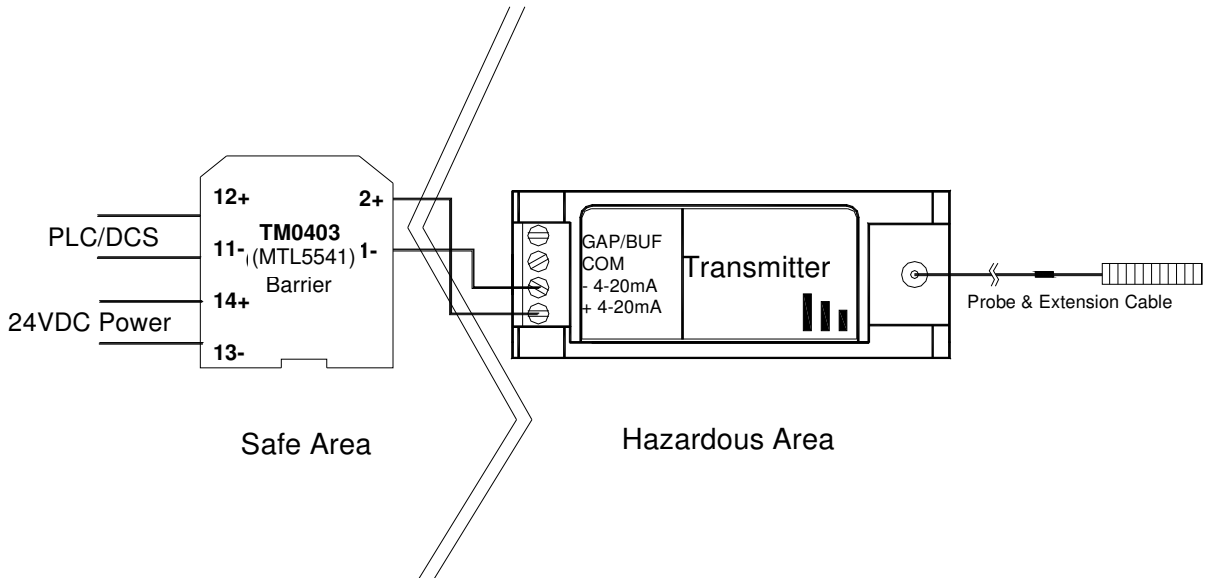
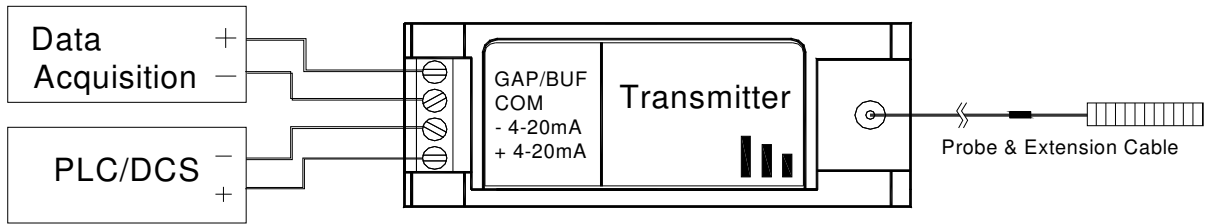

Note:

Other Barriers:

TM0406: (STAHL 9303/11-22-11)

TM0407: (STAHL 9160/13-11-11)

TR4102 Proximity Loop Powered Transmitter for Axial Position/ Phase Reference

The TR4102 is a cost-effective solution for monitoring the axial position or phase reference on balance of plant machines. The TR4102 combines the proximity probe driver and the signal conditioning circuit into one package. It works with a proximity probe and extension cable as a system.

Features

- ✓ **Loop powered transmitter**
- ✓ **Does not require proximity probe driver**
- ✓ **Buffered output/ GAP**
- ✓ **Compatible with other manufacturers' proximity probes (5mm, 8mm and 11mm)**
- ✓ **Aluminum cast case (copper free) with epoxy potting for better environmental protection and reliability**
- ✓ **Same size as a proximity probe driver**

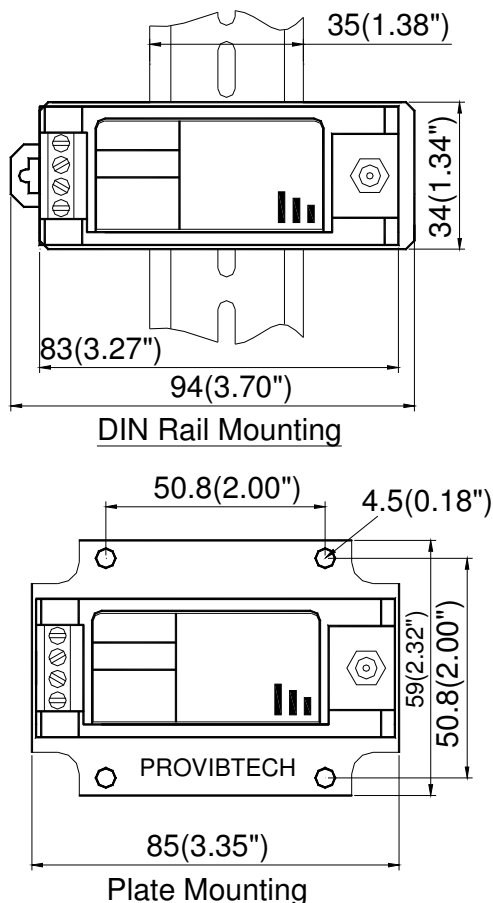

Specifications

Electrical

DCS or PLC Power Supply:

16-30VDC

Sensor Interface:

Special 95Ω coaxial cable with connector

Probe:

5mm, 8mm, and 11mm probes which includes: TM0180, TM0105, TM0110, 3300, and 7200 series

Sensor Linear Range (reference with AISI 4140 steel):

5mm, 8mm probe: 2.0 mm (80mil)

Approximately 0.25mm (10mil) to 2.25mm (90mil)

11mm probe: 4.0mm (160mil)

Approximately 0.4mm (15mil) to 4.4mm (175mil)

4-20mA Transmissions:

2-wire, load

Phase reference: frequency response: 0 - 10 KHz (G02 and G03)

Buffered Output (GAP V):

Raw position signal

Nominal: 2-18VDC

Impedance: 20KΩ

Maximum cable distance: 3.0m (10ft)

Sensitivity: 8mV/um (200mV/mil) nominal

Frequency response: 0 - 10 KHz

Maximum Load:

50×(Vs-16)

Where Vs is the system power supply

System Self-test:

System OK: output 4-20mA

System Not OK: output < 3.6mA

Physical

Height: 75mm (2.95")
Weight: 1.0kg (2.0 lbs)

Environmental

Temperature:
Operation: -40°C to +70°C
Storage: -40°C to +100°C
Humidity:
90% non-condensing

Order Information

* Factory default

Standard configuration:

TR4102-E00-G00-S00

8mm probe:

TM0180-07-00-05-10-02

Extension cable:

TM0181-040-00

TR4102-EXX-GXX-SXX

EXX: Probe and Cable

E00*: TM0180, 8mm Probe, 5m Cable
E01: TM0180, 8mm Probe, 9m Cable
E02: 3300, 8mm Probe, 5m Cable
E03: 3300, 8mm Probe, 9m Cable
E04: 7200, 8mm Probe, 5m Cable
E05: 7200, 8mm Probe, 9m Cable
E06: TM0105, 5mm Probe, 5m Cable
E07: TM0105, 5mm Probe, 9m Cable
E08: TM0110, 11mm Probe, 5m Cable
E09: TM0110, 11mm Probe, 9m Cable
E10: 3300, 11mm Probe, 5m Cable
E11: 3300, 11mm Probe, 9m Cable
E12: 7200, 11mm Probe, 5m Cable
E13: 7200, 11mm Probe, 9m Cable
E14: 3309 Probe, 5m Cable
E15: 3309 Probe, 7m Cable

GXX: Mount/ Function

G00: DIN rail mount, measure position
G01: Plate mount, measure position
G02: DIN rail mount, measure phase
G03: Plate mount, measure phase

SXX: Hazardous Area

S00*: Without approval. CE
S01: Multiple approvals
ATEX: II1G, EEx iaIICT4@Ta=-40°C ~ +70°C
KEMA06ATEX0217X
CSA: Non-incendive, Class I, Div. 2,
Groups A, B, C, D & T4
CSA: Intrinsically safe, Class I, Div. I,
Groups A, B, C & D, T4
PCEC: Ex iaIICT4
GOST R: 0ExiaIICT4X
CE Mark

TR4102 Accessories

The TR4102 requires a proximity probe and extension cable to work as a system.

TM0180: 8mm probe

TM0105: 5mm probe

TM0110: 11mm probe

TM0181: Extension cable

TM0200: 3-1/2 digit display unit

KS01: Probe holding system for reverse-mount probes

KS02: GAP tester for comfortable setting of probe distance

KS04: LoopChecker for dynamic testing of the complete measurement circuit

KS05: SensiChecker for easy determination of the loop sensitivity

BNC-2 : BNC Adaptor for portable data collector



Field-Wiring Diagram

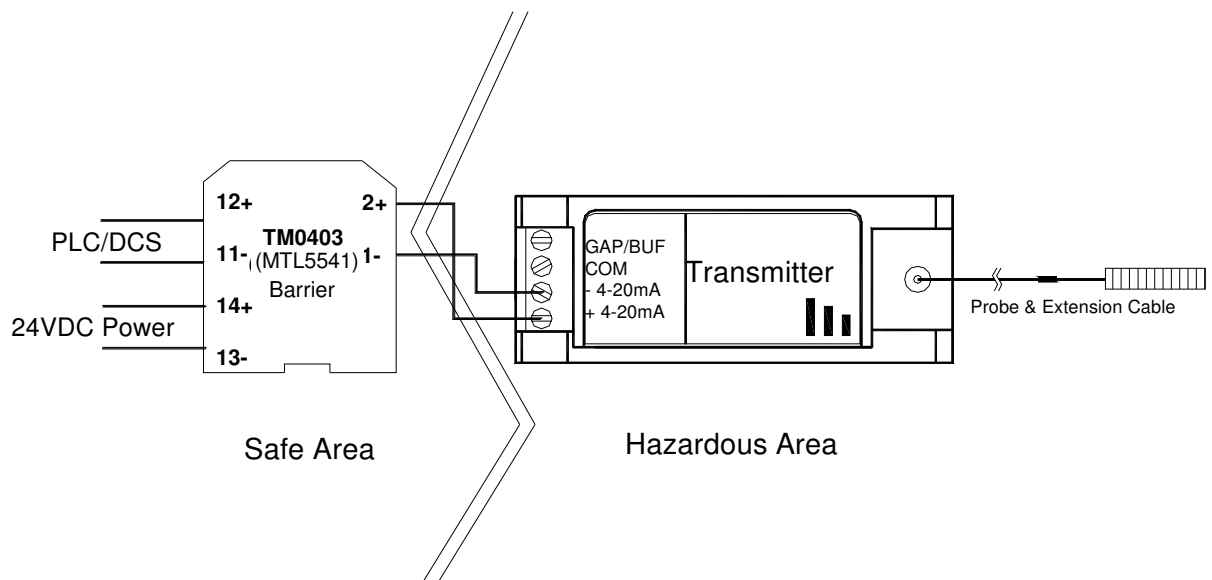
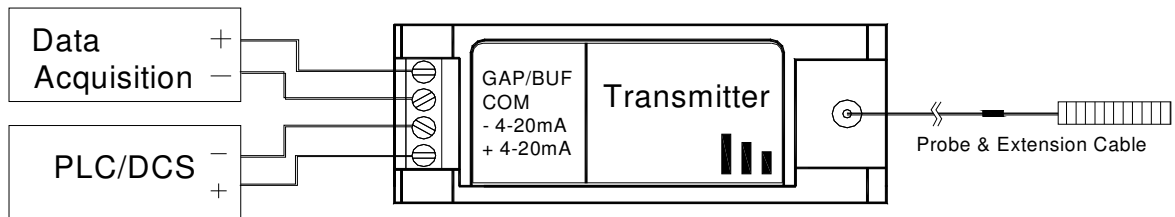

Note:

Other Barriers:

TM0406: (STAHL 9303/11-22-11)

TM0407: (STAHL 9160/13-11-11)

TM016 Velocity/ Acceleration Vibration Transmitter

Introduction

The TM016 is a solid state loop powered transmitter which provides a 4-20mA output proportional to the machine case vibration level. The 4-20mA output interfaces directly to any PLC or DCS for shutdown, alarm or trending. The TM016 is easy to install on the machine case.

Applications include:

- ✓ **Motors**
- ✓ **Pumps**
- ✓ **Fans**
- ✓ **Blowers**
- ✓ **Engines**
- ✓ **Compressors**
- ✓ **Centrifuges**
- ✓ **Generators**
- ✓ **Turbochargers**
- ✓ **Gear Boxes**



TM016-D0, D1

Features

- ✓ Loop powered 4-20mA velocity or acceleration (peak or RMS) output
- ✓ Wide operating temperature range -40°C to +120°C (-40°F to +248°F)
- ✓ Stainless steel housing
- ✓ NEMA4X, IP65 or IP67 environmental rating
- ✓ Multiple hazardous area approvals
- ✓ Frequency filter options
- ✓ Wide selection of mounting studs



TM016-D4

Electrical

Overall vibration output:

4-20mA, load (loop powered)

Accuracy: 3%

Frequency response ($\pm 3\text{db}$):

Acceleration:

AAA= 200, 201, 202: 2 - 3,000 Hz

Velocity:

AAA= 000 to 162: 2 - 3,000 Hz

Transverse sensitivity:

< 5%

Power supply:

12VDC - 30VDC

< 30mA

Maximum load resistance:

600 ohms @ 24VDC power supply

Isolation:

500Vrms, circuit to case

Case material:

Stainless steel

Output connection:

Flying leads:

2 cables for 4-20mA

2 cables for buffered output

Mil connector:

2 pins for 4-20mA

Buffered output:

100mV/g nominal

Maximum cable length 3m (10ft)

Filter option:

40dB/oct for hi-pass filter

40dB/oct for low-pass filter

Intrinsically safe:

ATEX: II 1G EEx iaIICT4 @Ta=-40°C to+100°C

(Ui=30V, Ii=110mA, Pi=825mW, Ci=51.7nF, Li=84uH)

PCEC: Ex iaIICT4

Physical

Temperature:

Operation:

Normal (G=0): -40°C to + 100°C (-40°F to +212°F)

High (G=1): -40°C to + 120°C (-40°F to +248°F)

Storage: -50°C to + 125°C (-58°F to +257°F)

Dimensions:

Diameter: 38mm (1.5")

Height: Flying leads: 78mm (3.1");

Mil connectors: 87mm (3.4")

Weight:

240g (0.5lb)

Output Connections:

2-pin MIL-C-5015

Flying leads: 2 or 4 wires

1 NPT

Environmental:

Flying leads: NEMA 4X, IP65

2-pin connector: IP67

Proximity Transmitters and Seismic Vibration Transmitters

Order Information

* Factory default

TM016-AAA-BCD-EF-G

AAA: Full Scale

AAA=000: 20mm/s (0.8ips), pk
AAA=001: 20mm/s (0.8ips), rms
AAA=121: 25mm/s (1.0ips), pk
AAA=122: 12.5mm/s (0.5ips), pk
AAA=123: 50mm/s (2.0ips), pk
AAA=124: 125mm/s (5.0ips), pk
AAA=132: 75mm/s (3.0ips), pk
AAA=151: 25mm/s (1.0ips), rms
AAA=152: 12.5mm/s (0.5ips), rms
AAA=153: 50mm/s (2.0ips), rms
AAA=154: 125mm/s (5.0ips), rms
AAA=162: 75mm/s (3.0ips), rms
AAA=200: 5.0g, pk
AAA=201: 10g, pk
AAA=202: 20g, pk

B: Mounting Adaptor

B=0: 1/4" NPT
B=1: 1/2" NPT
B=2: 3/8-24UNF X 1/2"
B=3: 1/2-20UNF X 1/2"
B=4: M8x1-12
B=5: M10x1.25-12

C: Hazardous Area and Approvals

C=1: CE
C=2*: CE Explosion Proof Approval (D=0, 1)
CSA: Class I, Div. 1, Groups A, B, C & D
Class II, Div. 1, Groups E, F, G & T4@Ta=-40°C to+120°C
ATEX: II 2G, Ex d IIC T4@Ta=-40°C to+120°C
KEMA06ATEX0275
PCEC: Ex d IIC T4
C=3*: CE Intrinsically Safe Approval
ATEX: II 1G Ex ia IIC T4@Ta=-40°C to+100°C
KEMA06ATEX0228
GOST R: 0ExiaIIC T4X
PCEC: Ex iaIIC T4

D: Connection

D=0: 4-20mA, flying leads
D=1: 4-20mA, flying leads with buffered output
D=4: 4-20mA, 2-PIN MIL connector (C=1, 3)

E: High-pass Filter

E=0: None
E=1: 5Hz
E=2: 10Hz
E=3: 20Hz
E=4: 50Hz
E=5: 100Hz
E=6: 200Hz

F: Low-pass Filter

F=0: none
F=1: 500Hz
F=2: 1000Hz
F=3: 2000Hz

G: Temperature

G=0: Normal temperature (-40°C to + 100°C)
G=1: High temperature (-40°C to + 120°C)

TM016-K1

Vibration transmitter kit includes:

TM016-D0 or -D1 with TM016-02

CE mark

CSA: Class I, Div. 1, Groups A, B, C & D

Class II, Div. 1, Groups E, F, G & T4

ATEX: II 2G, Ex dIIC T4 @Ta=-40°C to+120°C

KEMA06ATEX0275

Field-Wiring Diagram

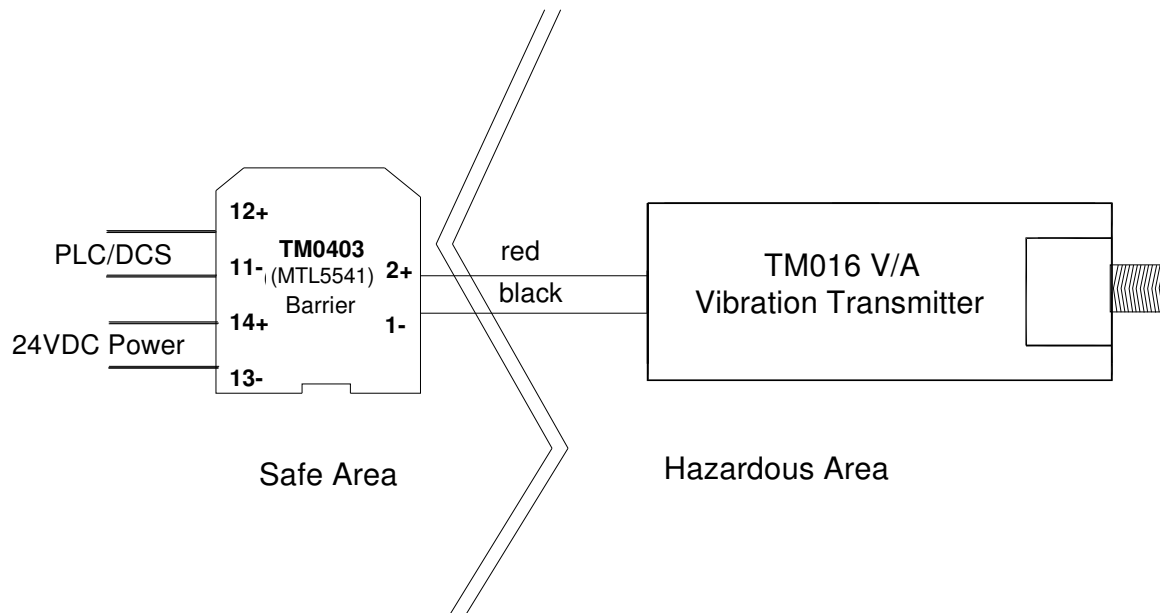
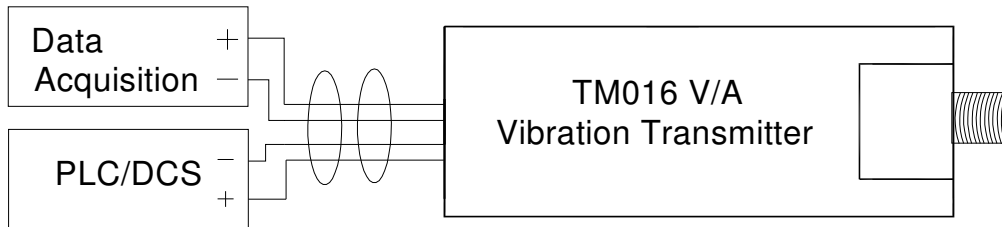

Note:

Other Barriers:

TM0404: (MTL 5542)

TM0406: (STAHL 9303/11-22-11)

TM0407: (STAHL 9160/13-11-11)

Proximity Transmitters and Seismic Vibration Transmitters

Accessories

(Standard cable length is 5 meters. XX = 05)



TM0702-XX: Aluminum MIL connector with XX meters cable, 6.35mm diameter.
< 120°C (250°F)



TM0703-XX: Sealed tight boot connector with XX meters cable, 6.35mm diameter.
< 120°C (250°F)



TM0704-XX: Stainless steel MIL connector with Armored XX meters cable,
4.83mm diameter. < 150°C (300°F)



TM0705-XX: Cornered MIL connector with XX meters cable, 6.35mm diameter.
< 120°C (250°F)



TM016-01: Aluminum conduit elbow & reducer. 1" to 3/4" NPT

TM016-11: Aluminum conduit elbow & reducer with terminal block. 1" to 3/4" NPT
Class I, Div. 1, Groups B, C & D; Class II, Div. 1, Groups E, F & G and NEMA 4X, IP65



TM016-02: Stainless steel conduit elbow with terminal block. 1" to 3/4" NPT
Class I, Div. 1, Groups A, B, C, D & T4; Class II, Div. 1, Groups E, F & G and NEMA 4X, IP65
(works with TM016)



TM016-03: Stainless steel flange mounting adaptor with 1/2" NPT mount; 3 holes of 7mm
on the circle of 38mm (1.5") in diameter

TM016-03:

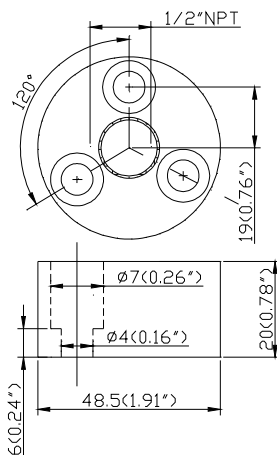

TM900: Power converter

TM0200: 3-1/2 digit display unit

Accessories: TM900 Power Converter

The TM900 power converter is designed for the DTM series transmitter-monitor and the TR 3-wire transmitter. Each TM900 supports up to seven DTM's and eight TR transmitters. The output of the power converter is isolated from its input. Additionally, the output is short-circuit protected and the input is ESD and fuse protected.

Specifications

Electrical

AC Power Input:
90-250VAC@200mA
Power Output:
Voltage: 24VDC±5%
Current: 800mA
Isolation:
1000VAC
Fuse:
2.0A, 250VAC

Physical

Height: 75mm (2.95")
Weight: 1.0kg (2.0 lbs)

Environmental

Temperature:
Operation: -40°C to +75°C
Storage: -50°C to +100°C
Humidity:
90% non-condensing



Certifications

CE certified with EMC compliance

Order Information

TM900-GX

GX: Mount

G0*: 35mm DIN-rail mount
G1: Plate mount

